

Contents

1	Operating and assembly instructions	1
2	General information on these instructions	1
2.1	Standards and guidelines	1
2.2	Intended use	2
2.3	Foreseeable misuse	2
2.4	Warranty and liability	2
2.5	Customer service provided by the manufacturer	2
3	Safety	2
3.1	General safety instructions	2
3.2	Layout of safety instructions	2
4	Product description	3
4.1	Product contents	3
4.2	Accessories	3
5	Assembly	3
5.1	Mechanical fastening	4
5.2	Electrical connection	4
5.3	Connection example: InDrive M30/1.6 RH 230 V / 50 Hz	5
5.4	Parallel circuit	5
5.5	Commissioning	5
5.6	Setting the end positions and release	5
5.6.1	Release function for end positions	5
5.6.2	Release function in initial position	5
5.6.3	Release function in end position	5
5.6.4	Changing/deleting end positions and deleting the release function	5
5.6.5	Four end position variants	6
5.6.6	Variant A: Initial position and end position freely adjustable	6
5.6.7	Variant B: Initial position at limit stop, end position freely adjustable	6
5.6.8	Variant C: Initial position and end position at limit stop	6
5.6.9	Variant D: initial position freely adjustable, end position at limit stop	7
6	Troubleshooting	7
7	Servicing	7
8	Service/manufacturer's address	7

9	Repairs	7
10	Disassembly and disposal	7
11	Conformity Declaration	8
12	Technical data and dimensions	8
12.1	InDrive M	8

InDrive M30/1.6 RH Actuator

1 Operating and assembly instructions

Follow these instructions for safe and proper use. Observe all assembly instructions since incorrect assembly can lead to serious injuries. Keep the instructions for future reference.

The German operating instructions are the original version.

All documents in other languages are translations of the original version.

All rights reserved in the case of patent, utility model or design registrations.

2 General information on these instructions

The content structure is based on the life cycles of the electric motor drive (hereinafter referred to as "the product").

The manufacturer reserves the right to make changes to the technical data in these operating instructions. In some cases, this technical data may differ from those of the respective product version; however, the functional information will not undergo significant changes or become invalid. The current version of the technical specifications may be requested from the manufacturer at any time. No claims may be asserted against the manufacturer as a result of this provision. Deviations from textual or visual statements may occur depending on the product's technical development, features and accessories. Deviating information for special versions will be provided by the manufacturer in the sales documentation. Other information shall remain unaffected by these provisions.

2.1 Standards and guidelines

During construction, the fundamental health and safety requirements were applied and provision was made for the appropriate legislation, standards, directives and guidelines. The safety of the product is confirmed by the declaration of conformity (see Declaration of Conformity). All information relating to safety in these operating instructions refers to the laws and regulations that are currently valid in Germany. All information in these operating instructions must be complied with at all times and without limitation. In addition to the safety notes in these operating instructions, the regulations on accident prevention, environmental protection and occupational health and safety applicable at the location of use must be observed and adhered to. The regulations and standards for safety assessment can be found in the Declaration of Conformity.

2.2 Intended use

The product is intended to drive electrically powered sun protection fittings, and in particular, louvre roofs.

Other applications must be agreed upon in advance with the manufacturer, **elero** GmbH Antriebstechnik (see "Address").

The plant operator shall be solely responsible for any damages arising from the improper use of this product. The manufacturer cannot be held liable for personal or material damages caused by misuse or procedural errors, nor by improper operation or commissioning.

The product may only be operated by instructed and authorised specialist personnel while observing all safety notes.

The safe and error-free use and operational reliability of the product are only guaranteed when it is used properly according to the specifications contained in these operating and assembly instructions.

Use according to its intended purpose includes the observation and compliance of all safety instructions contained in these operating instructions as well as all valid trade Accident Insurance regulations and valid laws on environmental protection. Use according to its intended purpose also includes the compliance with all prescribed operating regulations in these operating and assembly instructions.

2.3 Foreseeable misuse

Any use that deviates from the intended use as stated by the manufacturer, **elero** GmbH Antriebstechnik is deemed as foreseeable misuse.

2.4 Warranty and liability

The General Terms and Conditions of the manufacturer, **elero** GmbH Antriebstechnik, apply at all times. The conditions of sale and delivery are included in the sales documents and shall be presented to the plant operator upon delivery. Any liability claims for personal or material damages are excluded when they can be attributed to one or more of the following causes:

- Opening the product by the customer
- Improper use of the product
- Improper installation, commissioning or operation of the product
- Structural modifications to the product without the written consent of the manufacturer
- Operation of the product with improperly installed connections, defective safety devices or improperly installed safeguards
- Failure to observe the safety regulations and information presented in these operating instructions
- Failure to observe the specified technical data

2.5 Customer service provided by the manufacturer

In the event of a fault, the product may only be repaired by the manufacturer. The address for sending the product to Customer Service can be found in the "Address" section. If you did not purchase the product directly from **elero**, please contact the supplier of the product.

3 Safety

3.1 General safety instructions

General safety instructions for use of tubular drives can be found in the "Safety instructions" leaflet supplied with each drive (article number 138200001). These operating instructions contain all the safety information that must be observed in order to avoid and prevent danger when working with the product in the individual life cycles. When all specified safety instructions are complied with, safe operation of the device is guaranteed.

3.2 Layout of safety instructions

The safety instructions in this document are marked using hazard and safety symbols and are designed according to the SAFE principle. They contain information on the type and source of the danger, possible consequences and on avoiding danger.

The following table defines the representation and description of hazard levels with possible physical damage as used in these operating instructions.



Symbol	Signal word	Meaning
	DANGER	Warns about an accident that will occur if the instructions are not followed, which can lead to fatal, irreversible injuries or death.
	WARNING	Warns about an accident that may occur if the instructions are not followed, which can lead to serious, possibly fatal, irreversible injuries or death.
	CAUTION	Warns about an accident that can occur if the instructions are not followed, which can lead to slight, reversible injuries.

Fig. 1 Notation for personal injuries

The table below describes the pictograms used in these operating instructions to illustrate the hazard situation in relation with the symbol for the hazard level.

Symbol	Meaning
	Danger caused by electrical voltage, electric shock: This symbol indicates dangers due to electric current.

Fig. 2 Notation for specific danger

The table below defines the representation and description of situations used in these operating instructions for situations in which damage can occur to the product or indicates important facts, conditions, tips and information.



Symbol	Signal word	Meaning
	ATTENTION	This symbol warns against possible damage to property or equipment.
	IMPORTANT	This symbol indicates important facts and states as well as referring to further information in these operating and assembly instructions. It also refers to certain additional instructions, which provide additional information or help you to carry out a procedure more simply.
		Protection class I symbol

Fig. 3 Notation for damage to property and additional information

The following example illustrates the basic structure of a safety note:

SIGNAL WORD

Type and source of danger

Explanation of type and source of danger

- ▶ Measures to avoid the danger

4 Product description

The InDrive M30/1.6 RH is an electromechanical tubular drive for sun protection systems with horizontally moving slats. During operation it executes radial movements.

- Commissioning of the InDrive M30/1,6 RH with **elero** assembly cable for the configuration of various functions.
- Slat protection with free travel (torque limiting).
- Release function for the slats

4.1 Product contents

Drive with safety instructions and operating instructions and any additional components and accessories according to the order confirmation or delivery note.

4.2 Accessories

Connection and assembly cable, adapter sets, motor bearing, ProLine control units, sensors, receivers.

5 Assembly

 **WARNING**

Important safety instructions.

Observe all assembly instructions since incorrect assembly can lead to serious injuries.

- ▶ Commissioning of the InDrive M30/1.6 RH with elero assembly cable for setting various functions.
- ▶ Before installation, all cables and components that are not required and all facilities that are not needed for operation with a power drive are to be disabled.
- ▶ The required components are: drive, connection and assembly cable, motor bearing, adapter sets, if necessary rigid shaft connectors, sensors, control devices, receivers.
- ▶ If components are not delivered with the drive, these can

be identified via our catalogue "Drives and control units for intelligent building technology" in the relevant valid version. Further details can be found on our website under "Contact - Dealer Search" and "Contact - Partner Area".

- ▶ The rated torque and rated operating time must be suitable for the properties of the driven part (the slats of the sun roof).
- ▶ The coupling of the drive with the powered part is described in the section "Mechanical fastening".

 **CAUTION**

Risk of injuries due to hot surfaces.

The drive will heat up during operation, the drive casing can become hot. Skin burns are possible.

- ▶ Wear personal protection equipment (protective gloves).

Triggered by a possible material fault, knocks or impact injuries may arise due to a gear fracture, burring fracture or a coupling defect.

- ▶ Suitable materials have been used for the engineering design and random sample testing by means of a double load test has been performed in accordance with DIN EN 60335-2-97.

Risk of injury due to knocks or impact triggered by motor bearings that are incorrectly mounted or engaged. Hazard due to insufficient stability or steadiness and accumulated energy (gravity).

- ▶ Selection of motor bearing by torque specifications.
- ▶ The drive must be protected with all the enclosed safety devices.
- ▶ Check for correct engagement on motor bearing and the correct screw tightening torques.

 **WARNING**

Risk of injury due to electric current.



Risk of electric shock.

- ▶ Always have electrical work carried out by an authorised electrician.

Risk of injury due to electric current.



Possible danger due to parts that are faulty becoming energised.

- ▶ Electrical connection is described in the operating and assembly instructions, including cable routing.
- ▶ The drive falls under protection class I (protective conductor system). All housing parts of the drive capable of conducting electricity are connected with the protective conductor system of the fixed electrical installation, which is located at potential earth. The protective conductor connection is designed so that, the first time the plug is inserted, it is connected first and, in case of any damage, it is disconnected last. The connecting cable is fitted with mechanical strain-relief when inserted in the drive. If the cable is torn out, the protective conductor will be torn off last. If, in case of a fault, a live cable comes into contact with the housing, which is connected with the protective conductor, a short circuit will generally arise so that the fuse itself is triggered and de-energizes the electric circuit. No electricity will be conducted to human beings in case of a fault. 4-core connecting cables (4 x 0.75 mm² cross-section with black CONINVERS plug) are used for the electrical connection with an earthing contact that is conducted to the exterior.

 **CAUTION**

Risk of injury due to malfunctions as a result of incorrect assembly.

Drive is overwound and may destroy parts of the application.

- ▶ For safe operation, the end positions must be set/taught in.
- ▶ Manufacturer training is available for specialist companies.

ATTENTION



Power failures, breaking of machine parts and other malfunctions.

- ▶ For safe operation, assembly must be correct and the end positions must be configured upon commissioning.



Damage to InDrive M30/1.6 RH due to the penetration of moisture.

- ▶ On devices with protection class IP 44, the ends of all cables or plugs will need to be protected from ingress of moisture. This measure must be implemented immediately after removing the InDrive M30/1.6 RH from the original packaging.
- ▶ The drive must be installed so that it cannot get wet.

Important



In its delivery state (factory setting), the InDrive M30/1.6 RH will be in commissioning mode.

- ▶ The end positions will need to be configured (see section 5.6).

5.1 Mechanical fastening

Important preliminary consideration:

The working area around the installed drive is usually very small. For this reason, obtain an overview of how the electrical connection has been implemented prior to the mechanical installation (see section 5.2) and make the necessary changes beforehand.

ATTENTION



Crushing or tension will damage the electrical cables.

- ▶ Install all electrical cabling so that it is not subject to any crushing or tensile load
- ▶ Observe the bending radii of cables (at minimum 50 mm).
- ▶ Route connecting cables in a downward loop to prevent water running into the drive.



Damage to the drive due to the effect of impact forces.

- ▶ Slide the drive into the shaft. Never knock the drive in or use force!
- ▶ Take care not to drop the drive!



Damage or destruction to the drive by drilling.

- ▶ Never drill the drive!

Important



Only secure the InDrive M30/1.6 RH using the fastening elements provided for this purpose.

Fixed installed control devices need to be attached so they are visible.

- The profile tube must have sufficient clearance from the motor tube.
- Make sure there is sufficient axial play (1 - 2 mm)

Installation in profile tubes

- Ⓐ Push drive with relevant adapter and crown into the profile tube. Install the motor cable so it is protected to prevent damage from the driven part.

- Ⓑ Secure the counterpart support to prevent axial movement, e.g. screw or rivet on the idler. Secure the drive axially in the support!

- Ⓒ Attach the blind to the shaft.

The drive is fastened on the wall anchor and the blind mounted on the shaft using the suitable motor bearings and adapter components according to building requirements and, depending on the type of blind, with suitable connection elements, also provided by the system supplier.

Only operate the drive horizontally, as intended, with the connection cable leading out from the side and away from the slat movement area.

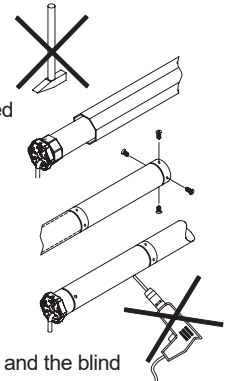

5.2 Electrical connection



WARNING

Faulty electrical connections constitute a fatal hazard.



Risk of electric shock.

- ▶ Prior to initial commissioning, check the PE wire is correctly connected.

ATTENTION



Damage to the InDrive M30/1.6 RH due to incorrect electrical connection.

- ▶ Prior to initial commissioning, check the PE wire is correctly connected.



Damage to or destruction of the InDrive M30/1.6 RH due to the penetration of moisture.

- ▶ For devices with protection class IP 44, the customer-side connection of the cable ends or plugs (cable feed-through) can also be implemented according to protection class IP 44.



Damage to or destruction of the InDrive M30/1.6 RH for variants with 230 V 1 AC due to incorrect activation.

- ▶ Switches for drives that are set to OFF by default (dead-man's switches) are to be installed within visible range of the InDrive M30/1.6 RH, but away from moving parts and at a height of more than 1.5 m.

5.3 Connection example: InDrive M30/1.6 RH 230 V / 50 Hz

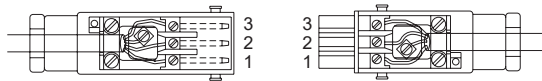
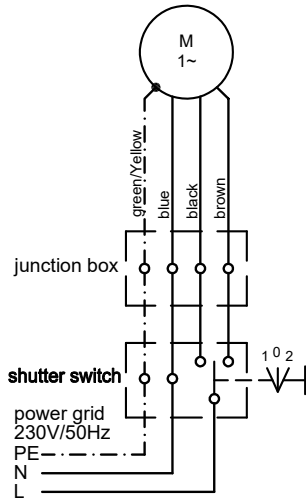

Fig. 4 Connection diagram InDrive M30/1.6 RH 230 V / 50 Hz and cable assignment when using Hirschmann plug connection STAS-3



Important

The motor controls in the up/down direction must be locked against each other.

A reversing delay of at least 0.5 seconds must be ensured.

5.4 Parallel circuit

Important



You can connect several InDrive M30/1.6 RH in parallel. Please note the maximum switching capacity of the control unit.

5.5 Commissioning

Important



The drive is in commissioning mode when delivered.

- ▶ The end positions must be configured using the **elero** assembly cable
- ▶ The assembly cable may only be connected to commission the drive and for adjustment operations

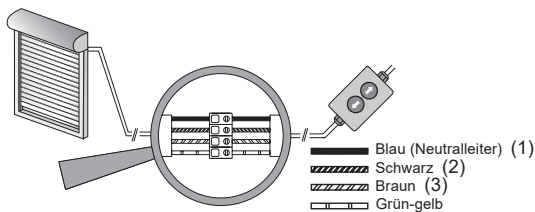

Fig. 5 Connection for assembly cable

- ▶ Switch on mains.
- ▶ You can now configure the end positions using the **elero** assembly cable.

5.6 Setting the end positions and release

Important preliminary consideration:

Decide on a specific release function before actually setting the end positions (different combination options as per the following designs).

This saves you unnecessary configuration work!

Press the adjustment keys until the drive signals the switch to programming mode by means of a short automatic stop. You can now set the end positions. Programming mode is finished once both end positions have been set.

5.6.1 Release function for end positions

If an end position was taught in at a limit stop, a release can also be enabled for the slats.

Important



The release function (for variants B to D) is activated in a single step when programming the end positions (see chapters 5.6.7 to 5.6.9)!

5.6.2 Release function in initial position

For variant B (see chapter 5.6.7) and variant C (see chapter 5.6.8):

Activate release function in initial position

- 1 Using the assembly cable while holding down the [UP ▲] button from instruction ① (chapters 5.6.7 and 5.6.8), press the [DOWN ▼] button (simultaneously) and hold down both buttons until the slats stop.

The release function in initial position is activated.

5.6.3 Release function in end position

For variant C (see chapter 5.6.8) and variant D (see chapter 5.6.9):

Activate release function in end position

- 1 Using the assembly cable while holding down the [DOWN ▼] from instruction ① (chapters 5.6.8 and 5.6.9), press the [UP ▲] button (simultaneously) and hold down both buttons until the slats stop.

The release function in end position is activated.

5.6.4 Changing/deleting end positions and deleting the release function

It is not possible to change or delete individual end positions. This is always done in pairs (initial position and end position at the same time).

When the end positions are deleted, the setting for the optional release function will also be lost.

Important



The protection for the slats is only adapted to the slats after a complete, uninterrupted extension and retraction (cycle).

Changing/deleting the end positions

- 1 Starting from a central slat position, use the assembly cable to simultaneously press both direction buttons [UP ▲] + [DOWN ▼] and hold them down until the slats briefly move up and down.

The end position settings have been deleted.

The end positions can be reset.

5.6.5 Four end position variants

Four different end position settings are possible. These can be selected as appropriate, according to the technical requirements of the slats.

End positions (4 variants)	
A	Initial position and end position freely adjustable
B	Initial position at limit stop, end position freely adjustable
C	Initial position and end position at limit stop
D	Initial position at limit stop, end position freely adjustable

Fig. 6 Variants of the end positions for the InDrive M

5.6.6 Variant A: Initial position and end position freely adjustable

Variant A:
Initial position and end position freely adjustable

- ① Starting from a central slat position, press the [UP ▲] button with the assembly cable until the slats have reached the desired initial position.
The drive begins to travel, briefly stops, and then travels further (for as long as the [UP ▲] button remains pressed).
You can make corrections using the [UP ▲] and [DOWN/CLOSE ▼] buttons.
- ② Press the [DOWN/CLOSE ▼] button until the drive stops automatically.
The initial position is set.
- ③ Press the [DOWN/CLOSE ▼] button again until the slats have reached the desired end position.
The drive begins to travel, briefly stops, and then travels further (for as long as the [DOWN/CLOSE ▼] button remains pressed).
You can make corrections using the [UP ▲] and [DOWN/CLOSE ▼] buttons.
- ④ Press the [UP ▲] button until the drive stops automatically.
The end position is set.

Adjustment of the variant A end positions is complete.

Fig. 7 End positions variant A:

5.6.7 Variant B: Initial position at limit stop, end position freely adjustable

Variant B: Initial position at limit stop, end position freely adjustable

- ① Starting from a central slat position, press the [UP ▲] button with the assembly cable until the slats have reached the desired initial position (travel to upper limit stop).
The drive begins to travel, briefly stops, and then travels further (for as long as the [UP ▲] button remains pressed).
The drive switches off automatically when it reaches the initial position.

Variant B: Initial position at limit stop, end position freely adjustable

- ② Press the [DOWN/CLOSE ▼] button until the drive stops automatically.
The initial position is set.
Optional: Activate the release function for the initial position: See chapter 5.6.2
- ③ Press the [DOWN/CLOSE ▼] button again until the slats have reached the desired end position.
The drive begins to travel, briefly stops and travels further (for as long as the button remains pressed).
You can make corrections using the [UP ▲] and [DOWN/CLOSE ▼] buttons.
- ④ Press the [UP ▲] button until the drive stops automatically.

Adjustment of the variant B end positions is complete.

Fig. 8 End positions variant B:

5.6.8 Variant C: Initial position and end position at limit stop

Variant C: Initial position and end position at limit stop

- ① Starting from a central slat position, press the [UP ▲] button with the assembly cable until the slats have reached the desired initial position (travel to limit stop).
The drive begins to travel, briefly stops, and then travels further (for as long as the [UP ▲] button remains pressed).
The drive switches off automatically when it reaches the initial position.
- ② Press the [DOWN/CLOSE ▼] button until the drive stops automatically.
The initial position is set.
Optional: Activate the release function for the initial position: See chapter 5.6.2
- ③ Press the [DOWN/CLOSE ▼] button again until the slats have reached the desired end position (travel to limit stop).
The drive begins to travel, briefly stops, and then travels further (for as long as the [DOWN/CLOSE ▼] button remains pressed).
The drive switches off automatically when it reaches the end position.
- ④ Press the [UP ▲] button until the drive stops automatically.
The end position is set.
Optional: Activate the release function for the end position: See chapter 5.6.3

Adjustment of the variant C end positions is complete.

Fig. 9 End positions variant C:

5.6.9 Variant D: initial position freely adjustable, end position at limit stop

Variant D: initial position freely adjustable, end position at limit stop

- ① Starting from a central slat position, press the [UP ▲] button with the assembly cable until the slats have reached the desired initial position. The drive begins to travel, briefly stops and travels further (for as long as the button remains pressed). You can make corrections using the [UP ▲] and [DOWN/CLOSE ▼] buttons.
- ② Press the [DOWN/CLOSE ▼] button until the drive stops automatically. The initial position is set.
- ③ Press the [DOWN/CLOSE ▼] button again until the slats have reached the desired end position (travel to limit stop). The drive begins to travel, briefly stops, and then travels further (for as long as the [DOWN/CLOSE ▼] button remains pressed). The drive switches off automatically when it reaches the end position.
- ④ Press the [UP ▲] button until the drive stops automatically. The end position is set.
Optional: Activate the release function for the end position: See chapter 5.6.3

Adjustment of the variant D end positions is complete.

Fig. 10 End positions variant D:

6 Troubleshooting

Problem / Error	Possible cause	Remedial action
• Drive stops during travel	• End positions are not set • Drive is in setting mode	• Configure end positions
• Drive stops after short time	• End position has been programmed • Stiff slats	• Set end position • Check the ease of movement of the slats
• Drive runs only in one direction	• Faulty connection	• Check connection
• Drive does not react	• No power supply • Temperature limiter has triggered	• Check mains voltage • Allow drive to cool down

Problem / Error	Possible cause	Remedial action
• End positions cannot be taught into the drive	• Random travel • Travel to end position or limit stop too short	• Delete end positions, re-programme end positions • Drive must move, stop briefly and continue its travel (as long as a button on the assembly cable is pressed).

Fig. 11 Troubleshooting for the InDrive M30/1.6 RH

7 Servicing

The InDrive M30/1.6 RH requires no maintenance.

8 Service/manufacturer's address

elero GmbH Drive technology Maybachstr. 30 73278 Schlierbach Deutschland / Germany	Tel: +49 7021 9539-0 Fax: +49 7021 9539-212 info@elero.de www.elero.com
---	--

Please visit our website if you require a contact partner outside Germany.

9 Repairs

Please contact your specialist if you have any questions. Please always provide the following information:

- Item number and designation on the type plate
- Type of fault
- Accompanying conditions
- Your own theories regarding the cause of the problem

10 Disassembly and disposal

After unpacking, dispose of the packaging in accordance with the valid regulations.

Dispose of the product in accordance with the relevant regulations when you no longer need it.

Environmental information

No superfluous packaging materials have been used. The packaging can be easily separated into three material types: cardboard (box), polystyrene (padding) and polyethylene (bag, protective foam).

The device is made of materials that can be reused if dismantled by a specialist company. Please note the local regulations on disposal of packaging materials and old appliances.

On disassembly, additional dangers must be reckoned with, which do not occur during operation.

Before disassembling the drive the system is to be mechanically secured. The drive must not be forcibly disconnected from the system.



WARNING

Risk of injury due to electric current.

Risk of electric shock.

- ▶ Separate power supply cables physically and discharge any energy accumulators still charged. After switching off the device, wait at least 5 minutes so that the motor can cool down and the voltage can be discharged from the capacitors.
- ▶ During disassembly work above head height, use suitable, inspected and structurally stable climbing aids.
- ▶ Work on the electrics may only be performed by personnel described in the section "Safety notes on electrical installation".

Removal for scrap

The international, national and regional laws and regulations prevailing at the time of scrapping the product must be observed.



Ensure that materials and components are recycled, dismantled and separated properly in addition to observing the environmental and health hazards relating to recycling and disposal.



CAUTION

Environmental damage in case of incorrect disposal

- ▶ Electrical scrap and electronic components must be handled as special waste and may only be disposed of by approved specialist companies.
- ▶ Groups of materials such as various types of plastics and metals must be separated before recycling/disposal.

Disposal of electrical and electronic components

The disposal and recycling of electrical and electronic components must be carried out in accordance with the relevant laws and national regulations.

11 Conformity Declaration

elero GmbH hereby declares that this product conforms with the applicable directives. For the full declaration of conformity, visit www.elero.com

12 Technical data and dimensions

The technical data specified is subject to tolerance factors (according to applicable standards) and refer to an ambient temperature of 20 °C.

12.1 InDrive M

InDrive	M30/1.6 RH
Rated torque [Nm]	30
Rated speed [rpm]	1.6
Rated voltage [V]	1 ~ 230
Rated frequency [Hz]	50
Noiseless soft brake	■
Rated current [A]	0.52
Rated power consumption [W]	118
Shaft diameter [mm]	50
Degree of protection (IP-Code)	44
Limit switch range (revolutions)	40
Operating time (min. S2)	4
Length C [mm]	469
Length D [mm]	452
Length E [mm]	12
Weight [kg]	1.9
Operating ambient temperature [°C]	-20 to 70
Protection class I	■
Conformity ,	-, -
Item No.	38 147.0001

